



BINTRAC[®]

Bin Weighing Systems

A better feed bin scale

Low cost, accurate and reliable

- Easy installation on existing and loaded bins using patented load cell bracket assembly
- Real-time bin inventory by weight
- 24-hour feed use for each of the past 4 days
- Feed delivery validation
- One-year warranty covers lightning damage to load cells – extended warranty available

U.S. Patent No. 7,980,129 and Patents Pending
Manufactured in USA by HerdStar



For additional information call 1-877-246-8722 or go to bintrac.com

From a single bin to a state-of-the-art web-based interface, BinTrac can be configured to meet your needs now and in the future.

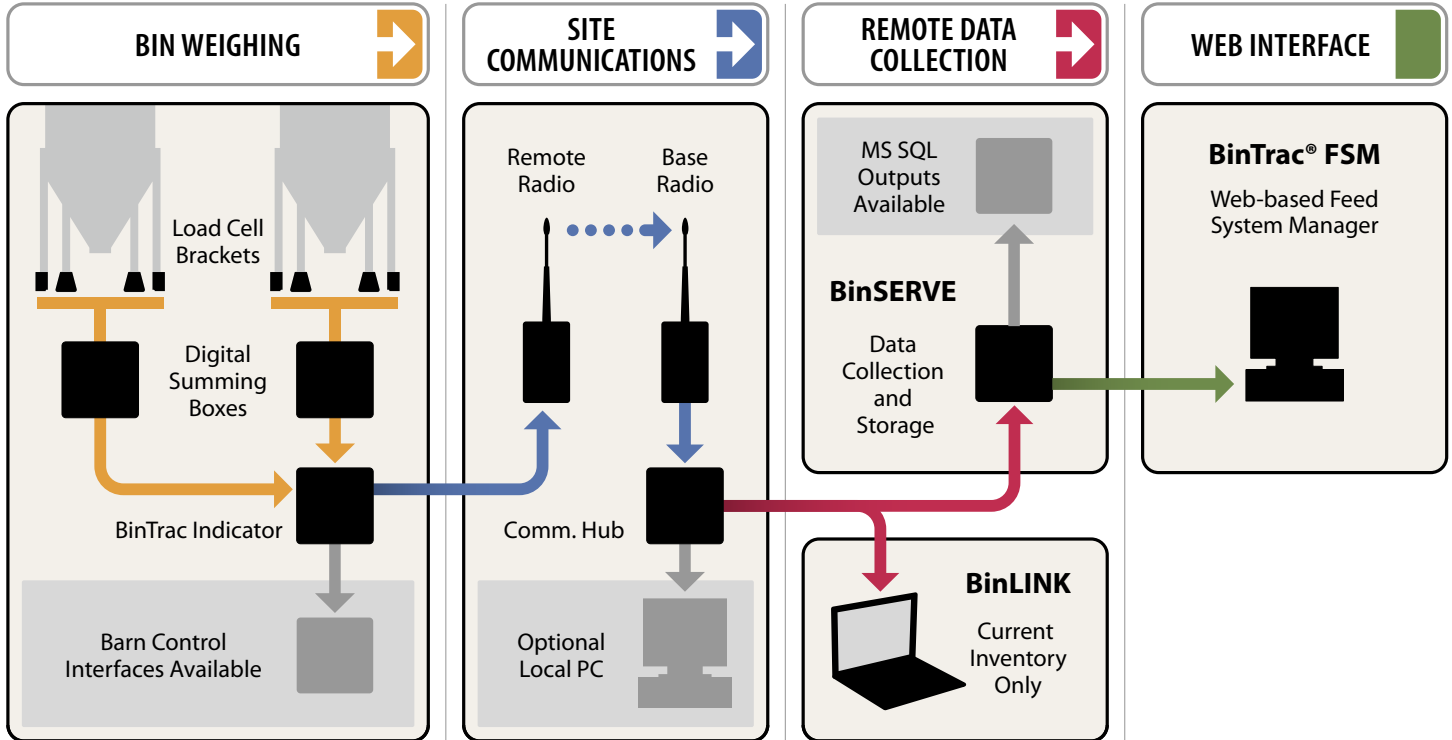

- Superior accuracy and reliability
- Local BinTrac indicator displays:
 - Current bin weight
 - 24-hour feed use
 - Recent fill weights
- Optional interfaces for barn control systems

- Access to bin data via wireless LAN
- Maximum 4-mile range
- Communications hub enables Local PC or remote data connection

- Remote data retrieval on two levels:
- BinSERVE provides hosted, automated data retrieval of current and logged data
 - BinLINK allows manual retrieval of current data only

- Hosted, web-based interface with:
- Current inventory and use rates
 - Customized reports
 - Alerts via web, text and email
 - Historical trending